



# Application for Water Utility Service Cedar Mountain/Long Valley

Phone: 435-644-3997 Fax: 435-644-8679 E-mail: kanecowater@gmail.com  
725 E. Kaneplex Dr., Kanab, UT 84741 www.kcwcd.com

For Water Service at (address):
Date Service Active (Will Use Recorded Deed Information if Available):

<b>Applicant:</b>	
<small>Last Names</small>	<small>First Name</small>
<b>Co-Applicant:</b>	
<small>Last Name</small>	<small>First Name</small>

Primary Phone:	Secondary Phone:	Other Phone:
<b>Mailing Address:</b>		
<small>Address</small>	<small>City</small>	<small>State</small>
		<small>Zip Code</small>

E-Mail Address:	Send My Bill By: <input type="checkbox"/> Mail <input type="checkbox"/> E-Mail
-----------------	---

### Employer Information

Applicant's Employer:	Co-Applicant's Employer:
Address:	Address:
City State Zip	City State Zip
Phone:	Phone:

### Emergency Contact Information

Name:	Phone:	Relationship:
-------	--------	---------------

<b>Water Rate Schedules (Effective July 1, 2023):</b>		
Usage Type	Rate	Water Included
Residential Level1-Base Rate ¾" meter	\$40.75	NO WATER- Applies to all meters regardless of activity
Residential Level1-Base Rate 1" meter	\$58.75	NO WATER- Applies to all meters regardless of activity
Residential Level1-Base Rate 1 1/2" meter	\$108.75	NO WATER- Applies to all meters regardless of activity
Residential Level1-Base Rate 2" meter	\$208.75	NO WATER- Applies to all meters regardless of activity
Residential Level1-Base Rate 4" meter	\$508.75	NO WATER- Applies to all meters regardless of activity
Residential Level1-Base Rate 6" meter	\$1,008.75	NO WATER- Applies to all meters regardless of activity
Residential Level 2- Plus \$3.00 per 1,000 gallons	\$3.00	1,000-10,000 Gallons per month
Residential Level 3- Plus \$3.25 per 1,000 gallons	\$3.25	10,001-15,000 Gallons per month
Residential Level 4- Plus \$3.50 per 1,000 gallons	\$3.50	15,001+ Gallons per month
Water Resource Management Fee – Per Month	\$3.00	Applies to all connections in the Duck Creek Area

The undersigned hereby applies (apply) to the Kane County Water Conservancy District (hereinafter the "District") for culinary indoor water service and permission to connect the premises listed above (hereinafter the "Property") to the District water system. The undersigned acknowledges the receipt of a copy of the Terms of Service. The undersigned hereby represent(s) and agree(s) to the Terms of Service individually and on behalf of the owner(s) of the Property, effective as of the date signed.

Applicant's Signature	Date	Co-Applicant's Signature	Date
-----------------------	------	--------------------------	------



# Application for Water Utility Service Cedar Mountain/Long Valley

Phone: 435-644-3997 Fax: 435-644-8679 E-mail: [kanecowater@gmail.com](mailto:kanecowater@gmail.com)  
725 E. Kaneplex Dr., Kanab, UT 84741 [www.kcwcd.com](http://www.kcwcd.com)

## Terms of Service

1. I (we) represent and warrant that I am (we are) the owner(s) of the property, or are trustees, partners, or other duly authorized representative(s) of the owner(s) of the Property, that I (we) have full power and authority to enter into this Agreement on our own behalf and on behalf of the owner(s) of the Property, and that the signature of no other person is required to bind the owner(s) of the Property to the terms of this Agreement. The term "I (we)" as used in this Agreement means and includes the signer(s) of this Agreement and individually the owner(s) of the Property if other than the signer(s) individually.
2. I (we) agree to pay all such charges for water service as are fixed from time to time by the District. I (we) understand that a base monthly fee for water service will be due even if no water is actually used on the Property. I (we) understand that the meter installed on the property is permanent and will not be removed for the purpose of not paying the base rate water fee.
3. I (we) agree that, unless installed already or otherwise agreed, the District shall install the necessary connection from its water main to a point on or near the Property line and shall install a water meter. I (we) understand that if not installed already, the District will endeavor to follow my (our) instructions as to the location of the water meter but ultimately the location of water lines, meter and related equipment shall be at the sole discretion of the District.
4. I (we) agree that if not installed already, all work and the cost of extending, maintaining, and repairing water lines from the meter to the point of use shall be my (our) responsibility, including any repairs needed to customer valve installed at the meter.
5. I (we) agree to pay all impact and connection fees, unless said impact and connection fees have been paid by a previous owner, and all other fees and charges, established by the District in connection with this Agreement and water services hereunder. I (we) agree that the District may file with the County Recorder a Notice of Lien against the Property to secure payment to the District of any impact, connection and other fees financed by the District.
6. I (we) agree that the District reserves the right to inspect the culinary water system servicing the Property, both on and outside of the Property, and to require any corrections or improvements, at my (our) expense, necessary to meet the requirements of the District or any other government agency having jurisdiction to regulate the water system of the District.
7. I (we) agree that I (we) and the Property will be bound by all rules, regulations, and ordinances enacted now or hereafter by the District applicable to the District's culinary water system.
8. I (we) represent that the main purpose or use to be made of this water connection is culinary indoor use.
9. I (we) agree to pay all taxes, mortgages, trust deeds, liens and other encumbrances against the property as they become due.
10. I (we) agree that in the event of any default hereunder, including failure to pay all sums due, whether for water service, District financed impact and connection fees or other District fees and charges, or for failure to pay all taxes, mortgages, trust deeds, liens and other encumbrances against the Property, or in the event of failure of the undersigned or any occupant of the premises to comply with the rules, regulations and ordinances established by the District or in the event of any other default, the District shall have the following rights and remedies, all of which may be exercised concurrently or separately at the election of the District, the exercise of one not constituting waiver or any other:
  - a. The District may terminate water service to the property fifteen (15) days after mailing of written notice of intent to terminate services. Termination of services shall continue until all delinquencies and all applicable reconnection fees and charges are paid in full and until all other conditions of default have been eliminated.
  - b. The District may declare the entire remaining balance of all sums due hereunder, including all charges for water service and all unpaid District financed impact and connection fees and all other District fees and charges, immediately due and payable and may collect the same by enforcing any Notice of Lien previously filed, or by filing and enforcing an original Notice of Lien if no Notice of Lien has yet been filed or by filing and enforcing one or more additional Notices of Lien if any Notice of Lien has been filed previously. Any lien filed against the Property shall remain on the Property until paid or satisfied, and shall include additional fees and charges occurring after the filing of such lien without any amendment of the Notice of Lien being required. All fees and charges in default and not timely paid shall bear interest at the rate of eighteen percent (18%) per annum until paid with a minimum monthly late charge of \$5.00. The District may enforce this lien by civil action, including recovery of its attorney's fees and costs of court, and including the right of foreclosure and sale of the Property in the event the lien remains unsatisfied for a period of three (3) months.
  - c. The District may certify to the appropriate county authorities all past due charges for water service, all unpaid District financed impact and connection fees, and all other unpaid District fees and charges, which fees and charges will become a lien on the Property on a parity with and collectible at the same time and in the same manner as general county taxes that are a lien on the Property.
  - d. The District shall have the right to specifically enforce by civil action compliance with its rules, regulations, and ordinances, including recovery of its attorney's fees and costs of court, whether or not related to a default in the payment of fees and charges.
11. I (we) agree that in the event of sale or other title transfer of the Property, I (we) will pay off the total balance owed to the District including all charges for water service, all unpaid District financed impact and connection fees, and all other District fees and charges. If payment is not made prior to closing, I (we) authorize and direct the closing agent to pay all outstanding fees and charges at the time of closing on written confirmation from the District of the amount due.

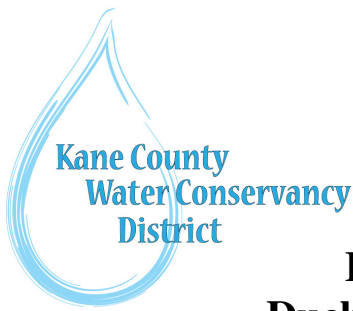

# KANE COUNTY WATER CONSERVANCY DISTRICT

725 E. Kaneplex Dr. • Kanab, UT 84741  
 (435) 644-3997 • Fax (435) 644-8679 • Email: kanecowater@gmail.com

## Kane County Water Conservancy District Duck Creek Water System Policies and Guidelines

### Cedar Mountain and Surrounding Area Monthly User Fee Schedule

Water Rate Schedules (Effective July 1, 2023):		
Usage Type	Rate	Water Included
Residential Level1-Base Rate ¾” meter	\$40.75	NO WATER-Applies to all meters regardless of activity
Residential Level1-Base Rate 1” meter	\$58.75	NO WATER-Applies to all meters regardless of activity
Residential Level1-Base Rate 1 1/2” meter	\$108.75	NO WATER-Applies to all meters regardless of activity
Residential Level1-Base Rate 2” meter	\$208.75	NO WATER-Applies to all meters regardless of activity
Residential Level1-Base Rate 4” meter	\$508.75	NO WATER-Applies to all meters regardless of activity
Residential Level1-Base Rate 6” meter	\$1,008.75	NO WATER-Applies to all meters regardless of activity
Residential Level 2- Plus \$3.00 per 1,000 gallons	\$3.00	1,000-10,000 Gallons per month
Residential Level 3- Plus \$3.25 per 1,000 gallons	\$3.25	10,001-15,000 Gallons per month
Residential Level 4- Plus \$3.50 per 1,000 gallons	\$3.50	15,001+ Gallons per month
Water Resource Management Fee – Per Month	\$3.00	Applies to all connections in the Duck Creek Area

\*Please note that base rates will be charged each month regardless of usage on the meter. This charge even applies to vacant lots.

As a new user of our water system, access to over 2.5 million gallons of storage is available to you and will be delivered at pressures between 50 and 150 PSI. The new pressurized system has been designed to meet all state and county fire protection regulations.

On the reverse side of this sheet, you will find a diagram detailing your meter and how to turn it on and off. Here are a few things to keep in mind when using your water:

- **ALWAYS** turn your water off at the customer valve by the meter when leaving your property. By doing so, you are keeping pressure out of the line to your house which can prevent leaks and a high water bill. Also, please make sure you always turn the valve completely to the on or off position to prevent excess water usage. (See diagram on back side for details)
- It is highly recommended that you install a pressure-reducing valve (PRV) on your side of the meter to prevent a line break. Kane County Code requires a PRV when the pressure is 80 PSI or greater.
- Maintenance of the customer valve (key, PVC extension, and extension cap) is the customer’s responsibility.
- If you need to access your meter inside of the barrel, please be sure to replace the foam plug securely on top of the meter and replace the meter lid. Any damage due to improperly covering the meter—rodent damage, freezing, etc. will be charged to the customer.
- Snow removal and access surrounding the meter is the customer’s responsibility. If you call for service and the snow around your meter has not been cleared, we cannot respond.
- Service calls will be charged at a rate of \$45.00 per hour with a 2 hour minimum plus the cost of any parts that are needed to repair damage incurred by the customer.
- The Kane County Water Conservancy District will maintain all equipment within the meter barrel and the blue marker.

If you have any questions regarding these policies or about the diagram on the back of this sheet, please call (435) 644-3997, or e-mail kanecowater@gmail.com

## Water Meter Barrel Detail—Side View

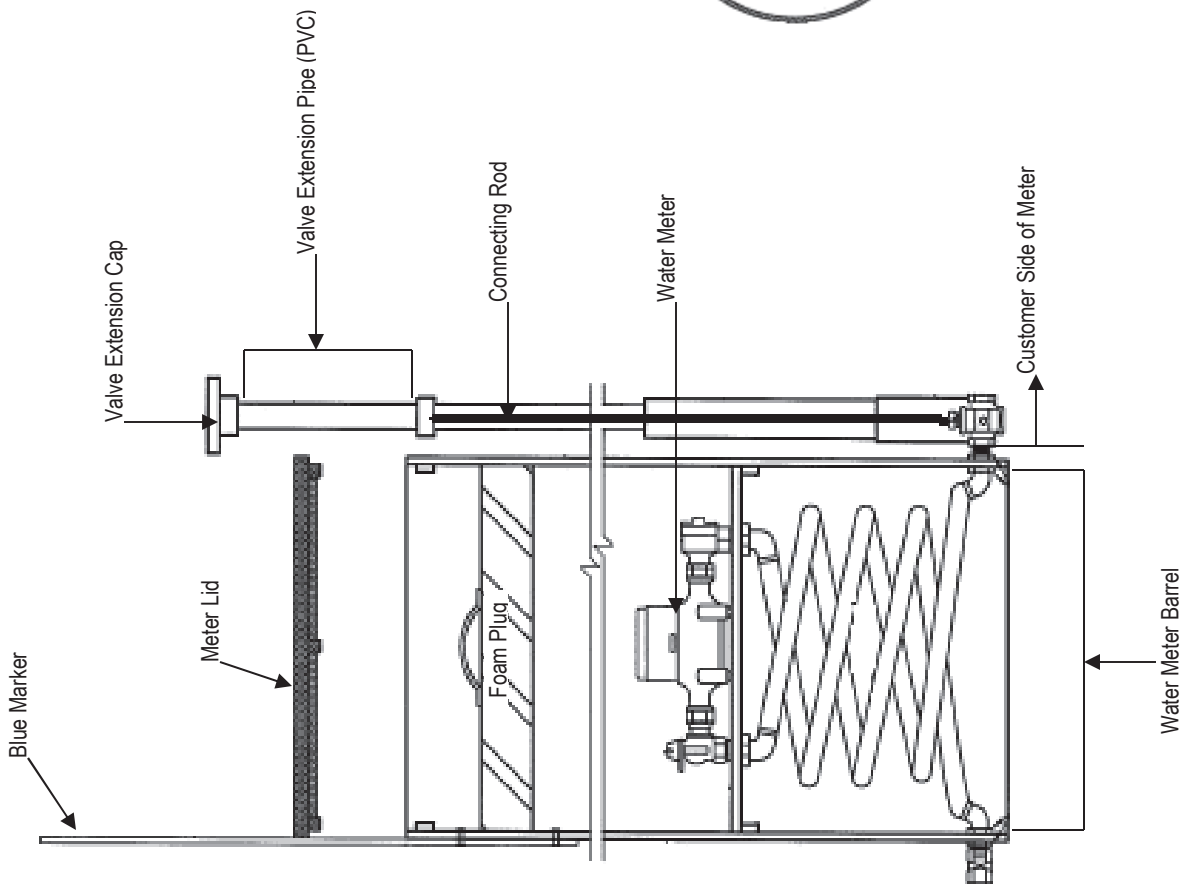

## Water Meter Barrel Detail—Top View

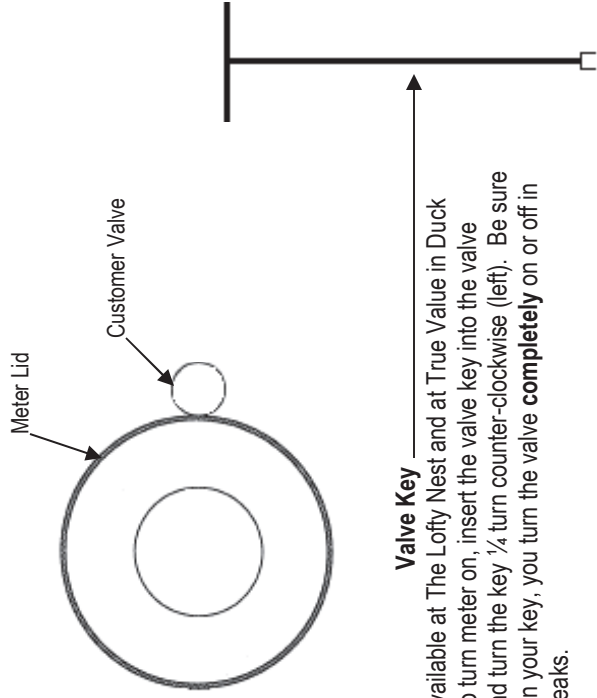

**Valve Key**

Valve keys are available at The Lofty Nest and at True Value in Duck Creek Village. To turn meter on, insert the valve key into the valve extension pipe and turn the key ¼ turn counter-clockwise (left). Be sure that when you turn your key, you turn the valve **completely** on or off in order to prevent leaks.

### Key In Off Position

Key will be parallel to the road when in the off position.

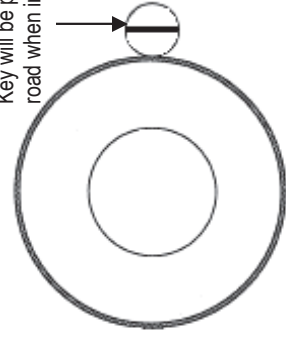

### Key Turning

Turn key ¼ turn counter-clockwise to turn meter on.

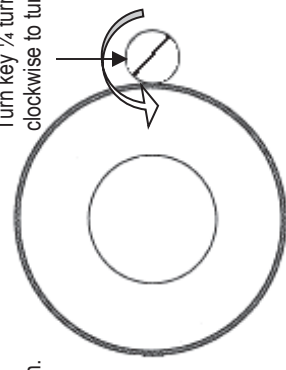

### Key In On Position

Key will be perpendicular to the road when in the on position.

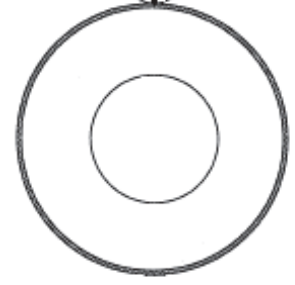

**IMPORTANT:** ALWAYS ensure that the valve is fully in either the on or off position. Leaving the valve partway between the on and off position will result in water running through the stop and waste valve, which registers as usage on your meter. This will result in high water charges on your bill.



# Application for Automatic Payment Service (APS)

Phone: 435-644-3997 Fax: 435-644-8679 E-mail: kanecobilling@gmail.com  
725 E. Kaneplex Dr., Kanab, UT 84741 www.kcwcd.com

Please consider paying your bill through electronic funds transfer, an easy way to pay a bill by an automatic draft from your checking or savings account each month. It will save you the time of writing a check and the cost of mailing it each month.

**To participate, please complete and return this electronic funds payment program authorization form to the Kane County Water Conservancy District (KCWCD). Please attach a voided check to this form to ensure timeliness and accuracy in processing your request.**

Service Address:	KCWCD Account#:
Name on KCWCD Account:	

## Checking Account Information

Name on Account:	<input type="checkbox"/> Checking <input type="checkbox"/> Savings
Bank Name:	
Bank Address:	
City	State
	Zip

Phone:	Routing#:	Account#:
--------	-----------	-----------

## AUTHORIZATION

I, \_\_\_\_\_ (please print), hereby authorize the KCWCD to draw monthly bank drafts on my bank account shown above for the payment of my monthly water bill. I understand that I can discontinue my participation in the electronic payment program by notifying the KCWCD in writing. Both the KCWCD and the bank also may terminate this agreement with 10 days written notice. I understand that the KCWCD reserves the right to limit participation in the program to customers whose accounts are in good standing.

Signature: \_\_\_\_\_ Date: \_\_\_\_\_

**Sign me up for paperless billing.** By requesting this service, you will receive **only** an electronic copy of your bill e-mailed to you each month. If you are also using auto-pay, you will receive a monthly credit of \$1.00. Please provide your e-mail below for this request to be effective.

E-mail Address: \_\_\_\_\_

## IMPORTANT!!!

**Please attach a check marked "VOID" to this authorization form.** The date of each withdraw will appear on your monthly billing statement.